

HIGHWAY DESIGN MANUAL

Chapter 17 Bicycle Facility Design

Revision 83

June 24, 2015

This page intentionally left blank.

**CHAPTER 17
BICYCLE FACILITY DESIGN**

<u>Contents</u>	<u>Page</u>
17.1 INTRODUCTION	17-1
17.2 OBJECTIVES	17-1
17.3 DESIGN APPROVAL DOCUMENTS	17-2
17.4 DESIGN OF FACILITIES FOR BICYCLISTS	17-4
17.4.1 Bicycle Facilities Design Policy	17-4
17.4.2 Definitions	17-4
17.4.3 Minimum Standards and Guidelines.....	17-5
17.4.4 Roadway Improvements	17-6
17.4.5 Shoulders	17-6
17.4.6 Wide Curb Lanes	17-7
17.4.7 Bicycle Lanes.....	17-9
17.4.8 Bicycle Routes	17-13
17.4.9 Bicycle Paths	17-13
17.4.10 Supplemental Bicycle Facilities	17-16
17.5 RECREATIONAL WALKWAYS AND SHARED-USE PATHS	17-20
17.5.1 Access for Persons with Disabilities.....	17-20
17.5.2 Design Considerations.....	17-20
17.6 CONSTRUCTION ISSUES	17-22
17.6 MAINTENANCE OF BICYCLE FACILITIES	17-22
17.7 REFERENCES	17-23

**CHAPTER 17
BICYCLE FACILITY DESIGN**

LIST OF EXHIBITS

<u>Number</u>	<u>Title</u>	<u>Page</u>
17-1	Wide Curb Lane.....	17-8
17-2	Wide Curb Lane with On-Street Parking	17-8
17-3	Bike Lane	17-10
17-4	Bike Lane with On-Street Parking	17-10
17-5	Typical Bicycle and Automobile Movements at Intersections	17-11
17-6	Bicycle Lanes Approaching Right-Turn-Only Lanes	17-12
17-7	Safety Railings along Bicycle and Shared Use Paths	17-19

Section	General Changes Effective 6/24/2015
17.3, 17.4, 17.4.1 and 17.4.4	Revised to make reference to the Capital Projects Complete Streets Checklist in Appendix A of Chapter 18. (Revised 6/24/2015).

This page intentionally left blank.

17.1 INTRODUCTION

Bicycling is a reasonable, legitimate and increasingly significant mode of transportation in New York State. Bicyclists of all ages and capabilities use the State's streets and highways. Therefore, it is the Department's policy to consider bicyclists as an integral part of our intermodal transportation systems. By improving our ability to move people and goods in the most efficient means possible, we help to realize the Department's air quality, mobility, safety and cost effectiveness goals.

Despite the importance of bicycling, many existing streets and highways do not adequately provide for this mode of travel. Therefore, the scoping and design approval documents for projects that are used by bicyclists should identify their needs, the objectives for meeting those needs, the design criteria, and all feasible alternatives. Designers are responsible for assuring project designs provide for safe, convenient and cost effective bicycle travel consistent with the objectives and design criteria developed during project scoping or preliminary design.

It is important that the cost effectiveness of all proposed facilities be taken into consideration when a project is being designed. For example, facilities specifically for bicycling may not be needed on low speed or low volume roadways such as some local streets and rural roads, as well as on all highways where bicycling is not permitted. However, there is a potential decrease of safety, convenience and travel efficiency as traffic volumes and speeds increase on facilities where significant numbers of motor vehicles and bicycles must share travel ways and shoulders that do not include appropriate provisions for the anticipated users.

17.2 OBJECTIVES

This chapter provides design guidance for bicyclist facilities that are to be included in Department projects in order to meet needs identified during project scoping or preparation of the design approval documents. Minimum design standards and guidelines are included or referenced to assist in the selection and design of facilities.

17.3 DESIGN APPROVAL DOCUMENTS

Accommodation of bicyclists should be considered at the earliest scoping phases of every project. The failure to do so may have significant impacts on project costs, schedule, right-of-way needs and highway geometrics if it is not determined that accommodations are needed until detailed design has begun. Furthermore, FHWA policy (23 CFR 652.5) requires that the safe accommodation of bicyclists should be given full consideration during the planning, design and construction phases of Federal-Aid highway projects. The Department has determined that this policy also applies to 100% state funded projects.

The Capital Projects Complete Streets Checklist (Appendix A in HDM Chapter 18) is required for all projects. The checklist documents and highlights the potential for Complete Streets Design features at the project location. The checklist should be initiated at the earliest stages of the project and revisited throughout scoping and design. See HDM Section 18.5.1 for guidance on the use of the checklist.

Information on bicyclists' needs and activity may be obtained through use of methods such as:

- Observation
- Discussions with local governments and planning organizations
- Public informational meetings
- Accident reports
- Questionnaires
- Community organizations addressing the needs of persons with disabilities, bicyclists and pedestrians

Professional judgment must be exercised to assure that potentially conflicting information is satisfactorily reconciled. The Regional Bicycle and Pedestrian Coordinator should also be consulted for additional information and assistance.

An appropriate discussion of the following factors should be included in the bicycling sections of the Design Approval Document

1. Existing and expected land use patterns and generators of bicycle traffic:
 - a. Land use - residential, business/commercial, mixed commercial/residential, industrial, recreational, educational, agricultural and open space.
 - b. Specific bicycle traffic generators - major employment centers, schools, parks, shopping centers, residential neighborhoods, medical centers, colleges and universities, bus stops, transit stations, recreation areas, etc.
2. Existing and anticipated bicyclist characteristics:
 - a. Bicyclist use - weather conditions, time of day, holidays, school schedules and similar factors should be considered and noted when taking counts or characterizing use (i.e. infrequent, occasional, frequent, heavy, etc.).
 - b. User groups - i.e. commuters, students, children, adolescents, tourists.

- c. Trip purpose- utilitarian (shopping/errands; commuting to work, school or place of recreation) or recreational (visiting friends; neighborhood riding; or touring.)
 - d. Frequency of use - daily, week-ends, seasonal (as in tourist areas).
3. Existing site accommodations and characteristics:
 - a. The location of existing bicycle facilities, shoulders and worn paths.
 - b. The location of incomplete bicycle facilities that adjoin or are located within the right-of-way.
 - c. Existing bicycle facility signs.
 - d. The physical condition of the existing bicycle facilities.
 - e. Any site constraints or structural features that enhance or reduce feasibility of constructing bicycle facilities.
 - f. Existing right-of-way and availability of right-of-way.
 - g. Existing parking facilities, surface conditions, drainage, pavement markings, street lighting, and signage.
 4. Existing local government and/or regional transportation plans which identify existing or proposed bicyclist facilities.
 5. Bicyclist accident history.

Specific features that address the project's needs, objectives and design criteria are discussed for each alternative included in the feasible alternative(s) section of the Design Approval Document. Similarly, the scoping and Design Approval Documents should clearly document decisions that specific features to accommodate bicycle traffic are not needed.

The Department's minimum standards and guidelines for bicyclist facilities are included or referenced in this chapter. If the minimum standards can not be fully satisfied, the designer should provide a brief explanation in the Design Approval Document. The information provided in the Design Approval Documents should be similar to that given for justification of non-standard features (see Chapter 2, Section 2.8 and Chapter 5, Section 5.1).

17.4 DESIGN OF FACILITIES FOR BICYCLING

Bicyclists have the same rights and responsibilities as the operators of motor vehicles, except as provided in Sections 1230-1236 of the "New York State Vehicle and Traffic Law".

When designing highway projects, it is essential to consider physical improvements for bicycles just as for other vehicles in the traffic mix. Therefore, all state highways should be designed and constructed to safely accommodate known and anticipated bicycle traffic consistent with the needs identified by the Capital Projects Complete Streets Checklist during project scoping. If a need for bicycle facilities is identified but cannot be provided, an explanation should be provided in the Design Approval Documents.

Special consideration should be given to routes that have been mapped by MPOs, or have been identified in other local or state bicycle transportation plans. Also, special consideration should

be given in areas near schools and residences. Significant numbers of children using a highway or path may require special signage that will alert others to their presence.

17.4.1 **Bicycle Facilities Design Policy**

Highways and streets where bicyclists are permitted should provide for safe and convenient bicycling. However, not every highway or street requires the provision of specific bicycle facilities in order to improve bicycling conditions. The Capital Projects Complete Streets Checklist should be completed to help identify where facilities for bicyclists are needed and should be provided. These needs can usually be met through the use of wide curb lanes, bike lanes and/or paved shoulders of adequate width.

17.4.2 **Definitions**

Bicycle facilities - A general term denoting improvements and provisions made by public agencies to accommodate or encourage bicycling. These include bicycle parking facilities and shared roadways.

Bicycle lane - A portion of a roadway which has been designated by striping, pavement markings and signing for the preferential use of bicyclists.

Bicycle path - A path that is physically separated from motor vehicle traffic by an open space or barrier and may be in the highway right-of-way or an independent right-of-way.

Bicycle route - A system or network of roads, streets, paths or ways that are open to bicycle travel and that have been designated by the jurisdiction(s) having authority with appropriate directional and informational route markers (with or without a specific bicycle route number). Established bicycle routes should provide for continuous routing between logical termini.

Shared roadway - A roadway which may or may not be designated and marked as a bicycle route, but which is open to both bicycle and motor vehicle travel and upon which no bicycle lane is designated. Examples may include roads with wide curb lanes and roads with shoulders.

Wide curb lane - The right-most through traffic lane that has a minimum usable width of 3.6 m.

17.4.3 **Minimum Standards and Guidelines**

The current edition of the AASHTO "Guide for the Development of Bicycle Facilities" establishes the minimum requirements for the design and construction of bicycle facilities on Department projects. This is consistent with the provisions of 23 CFR 652.13 which establishes the AASHTO Guide as FHWA's standards for construction and design of bicycle facilities.

The FHWA's manual "Selecting Roadway Design Treatments to Accommodate Bicycles" (Publication No. FHWA-RD-92-073) provides guidance about the types and recommended widths of typical on-road bicycle facilities that may be constructed to address needs identified in project Design Approval Documents.

The report uses five criteria to help select the most appropriate type and width of facility for a particular project. The criteria are:

1. motor vehicle traffic volume
2. average motor vehicle operating speed
3. traffic mix of automobiles, trucks, busses and/or recreational vehicles
4. on-street parking
5. sight distance

Six tables were developed based on the criteria. They provide bicycle facility type and width recommendations for urban and rural roadway sections for two different types of "design bicyclists" (i.e., experienced or advanced bicyclists and basic adult or young bicyclists). Advice regarding use of the report can be obtained from the Regional Bicycle and Pedestrian Coordinator and/or from the regional landscape architectural staff. The report is not a standard, nor is it a comprehensive guide to the design of bicycle facilities. It is intended to provide a rational and consistent method for determining appropriate widths for accommodating bicyclists on roadways. As many of the report's conclusions and recommendations are based upon the author's professional judgments, the report should be used as guidance only and should not be used as the only reference for decision making where its guidelines cannot be met.

Under some circumstances, the tables provided in the report recommend shoulder, wide curb lane and/or bicycle lane widths that are wider than the Department's or FHWA's standard widths. In those situations designers should use the Department and FHWA standards presented or referred to in this Chapter.

17.4.4 Roadway Improvements

Many existing highways were not designed with bicycle travel in mind. However, there are usually reasonable ways in which they may be improved to more safely accommodate bicycle traffic. Therefore, roadway conditions should be examined during scoping and design whenever highways are being constructed, reconstructed or resurfaced. The need for drainage grates, railroad crossings, pavements, traffic control devices, railings and other roadway adaptations that are responsive to bicyclists' requirements should be discussed in the scoping and design approval documents. These documents should discuss any decisions made regarding whether or not improvements that would better accommodate bicycling are incorporated into projects.

Roadway improvements that enhance bicycling can be implemented in many highway projects. Use the Capital Projects Complete Streets Checklist (Appendix A in HDM Chapter 18) to help identify the need for bicycle facilities. Design alternatives that provide roadway improvements such as adequate shoulders, wide curb lanes or bicycle lanes should be developed and considered. Designers should consult with the Regional Bicycle and Pedestrian Coordinator; and refer to the current AASHTO "Guide for the Development of Bicycle Facilities", the information provided below, and other sources identified in this chapter. For specific guidance related to drainage grates, railroad crossings, pavement surfaces and traffic control devices, designers should refer to the current AASHTO "Guide for the Development of Bicycle Facilities".

17.4.5 Shoulders

Shoulders that are well designed for bicycling will also have maintenance, safety and other benefits that affect other highway users. AASHTO defines paved shoulders, together with the adjacent travel lane, as shared use facilities on roadways where bicycling is permitted.

When the Capital Projects Complete Streets Checklist (Appendix A in HDM Chapter 18) or Design Approval Document indicates a need to design shoulders on a project to specifically accommodate bicycling, the shoulder width should be a minimum of 1.2 m (4 ft). The designer should also consult with the Regional Bicycle and Pedestrian Coordinator, regional landscape architectural staff and the Regional Traffic Engineer; and should refer to the current AASHTO "Guide for the Development of Bicycle Facilities" and FHWA's "Selecting Roadway Design Treatments to Accommodate Bicycles" for guidance.

When a project involves a roadway that is also an existing or planned bicycle route and that includes long, steep grades, the designer should consider providing additional width on the downhill shoulders. Bicyclists traveling downhill frequently will reach high rates of speed and may find that narrow shoulders, 1.2 m (4 ft) or less, are unusable when debris and litter have accumulated on them, or bicyclists may not trust unseen shoulder conditions ahead. These factors may cause bicyclists traveling downhill on the shoulder to weave out into the travel lane in order to assure a smooth, sound riding surface. This potential problem may be alleviated if the travel lane is wide enough to accommodate the expected bicycle and motor vehicle traffic, or if at least a 1.8 m wide shoulder is provided on downgrades exceeding 5% and that are more than 1 km (0.62 mi) in length. In urban areas, a 4.2 m (13.8 ft) wide curb lane (including curb offset) is desirable. Designers should refer to Section 17.7.7 for a discussion of bicycle routes.

The recommended shoulder widths on projects designed specifically to accommodate bicycling may exceed the minimum shoulder widths shown in the NYSDOT "Standards for Non-Freeway Resurfacing, Restoration and Rehabilitation Projects" (3R Standards) dated July 1, 1992. Widths in excess of the minimum widths outlined in the 3R Standards should only be provided where needs for specific provisions to accommodate bicycling have been identified in the scoping or preliminary design phase.

17.4.6 Wide Curb Lanes

Wide curb lanes are shared use facilities where motor vehicles and bicycles are both accommodated in a wider travel lane. AASHTO's "Guide for the Development of Bicycle Facilities" states a usable pavement width of 4.2 m is desired. The Guide also indicates that where this width cannot be achieved, the curb lane should have, at a minimum, 3.6 m of usable pavement. Usable pavement width is from curb face to the center of the lane stripe, or from edge line to the center of the lane stripe, but adjustments need to be made for drainage grates, parking, and longitudinal joints between pavement and gutter sections (see Fig. 17-10).

Where an edge stripe is used on a wide curb lane, the stripe should be placed as close as practicable to the curb face. However, where this has the potential for encouraging the undesirable operation of two motor vehicles in one lane, it may be preferable to place the edge

stripe at the edge of the travel lane, provided that a 1.2 m wide "shoulder" space (approximate) would remain between the curb face and lane stripe. For more information on wide curb lanes and the placement of edge stripes, the designer should refer to the current AASHTO "Guide for the Development of Bicycle Facilities" and FHWA's "Selecting Roadway Design Treatments to Accommodate Bicycles". In addition, the designer should consult with the Regional Bicycle and Pedestrian Coordinator, regional landscape architectural staff and Regional Traffic Engineer.

The minimum widths given for wide curb lanes in this Chapter or recommended in "Selecting Roadway Design Treatments to Accommodate Bicycles" may be greater than the minimum widths shown in Chapter 2, Section 2.7 or NYSDOT's "Standards for Non-Freeway Resurfacing, Restoration and Rehabilitation Projects" (3R Standards) dated July 1, 1992. Widths in excess of the minimum widths outlined in Chapter 2 or the 3R Standards should only be provided where needs for specific provisions to accommodate bicycling have been identified in the scoping or preliminary design phase. If curb lane widths greater than 4.2 m are proposed, the use of bike lanes (see Section 17.4.7) should be considered in order to prevent the undesirable operation of two motor vehicles in one lane.

For information related to bicycle safe drainage grates, consult Chapter 8, Section 8.04.06 of this manual and FHWA's "Bicycle Safe Grate Inlet Study".

Wide curb lanes may offer the following advantages:

- Provide additional maneuvering room for motorists and bicyclists sharing the lane.
- Normally provide motorists entering the highway with better visibility of bicyclists since the additional space allows bicyclists to ride further from the curb. As a result they are more likely to be within motorists' cone of vision.
- Accommodate shared bicycle/motor vehicle use with little or no impact on roadway capacity for vehicular traffic.
- Reduce both the real and perceived operating conflicts between bicycles and motor vehicles.

Exhibit 17-2 indicates the preferred method of providing shared travel lanes where there is on-street parking.

Exhibit 17-1 Wide Curb Lane

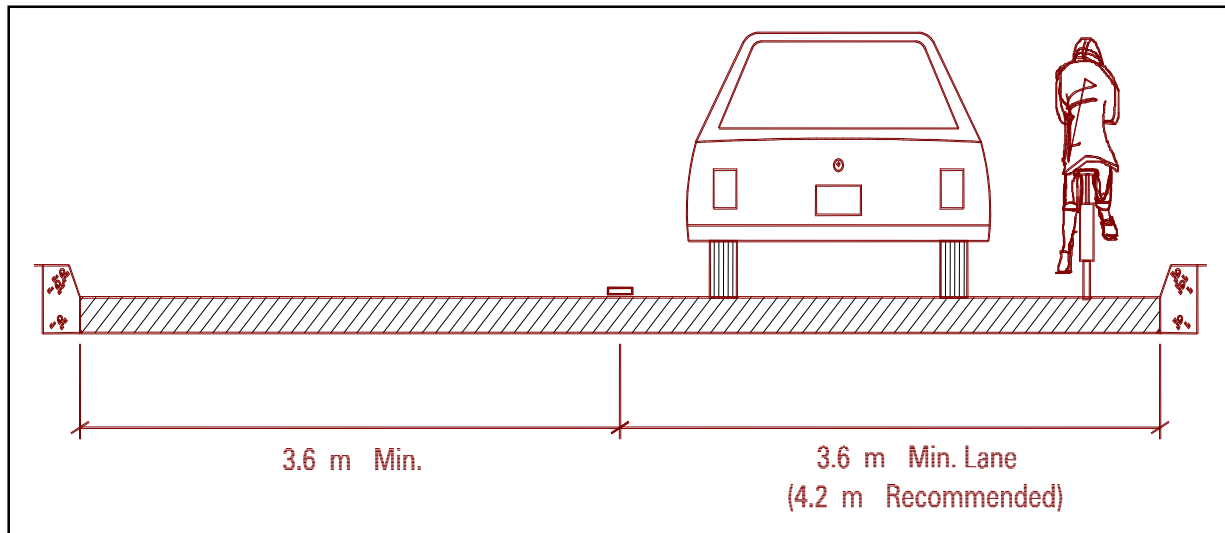
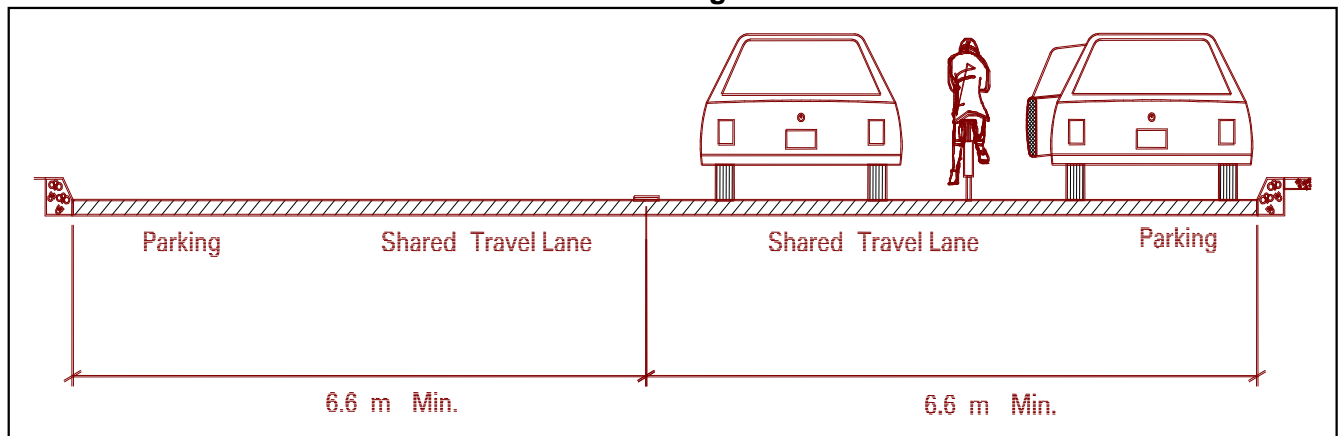

Exhibit 17-2 Wide Curb Lane with On-Street Parking



17.4.7 Bicycle Lanes

Bike lanes are intended to promote the orderly flow of traffic by establishing specific lines of demarcation between areas reserved for bicyclists and lanes occupied by motor vehicles. This effect is supported by bike lane signs and pavement markings. Bike lanes can increase bicyclists' confidence that motorists will not stray into their path of travel if the bicyclist remains in the bike lane. Likewise, with more certainty as to where bicyclists will be, passing motorists may not feel as though they must move out of their lane to assure they will not hit bicyclists.

Bicycle lanes can be especially useful for inexperienced and youthful riders. These riders tend to travel at lower speeds and may benefit from the additional space to travel in. Bicycle lanes offer designated and visible spaces for bicyclists and can be a significant factor in route choice.

Bicycle lanes may be incorporated into a roadway when the need to do so is identified in the project scoping and design approval documents. Bicycle lanes are uniformly wide portions of roadways designated by signing, striping and other pavement markings for preferential use by bicyclists (see Figures 17-3 and 17-4). Bicycle lanes help to provide for more predictable movements by both bicyclists and motorists (see Fig.17-5).

When the project scoping and design approval documents identify the need or desirability of bicycle lanes, designers should refer to the current AASHTO "Guide for the Development of Bicycle Facilities" and FHWA's "Selecting Roadway Design Treatments to Accommodate Bicycles" for information on the use and recommended width of bicycle lanes. Designers should also consult with the Regional Pedestrian and Bicycle Coordinator, regional landscape architectural staff and Regional Traffic Engineer and should consider the following:

- Two-way bicycle lanes on one side of a highway are not acceptable because they promote riding against the flow of motor vehicle traffic. This practice is specifically identified as an illegal operation of a bicycle in the "Vehicle and Traffic Law".
- Bicycle lanes should not be placed where angled parking is provided.
- Figure 17-5 presents examples of pavement markings for bicycle lanes at intersections. In establishing the length of the bicycle lanes, consideration must be given to the point of conflict between bicyclist and motorist (i.e. where right turning motorists must cross a bicyclist's path). The conflict point should be located where there will be the least differential in speed. As bike lanes approach intersections, they should be dropped at the beginning of a right turn lane. However, right turn lanes should be wide enough to accommodate bicyclists until they are able to safely cross the right turn lane to get into the through bicycle lane. The length of the merging space should be approximately 60 m.
- Where there are numerous left-turning bicyclists, separate turning lanes, as indicated in Part IX of the Federal MUTCD, should be considered.

BICYCLE FACILITY DESIGN

- The design of bicycle lanes should also include appropriate signing and pavement markings at intersections to reduce the number of conflicts. General guidance for pavement marking of bicycle lanes is contained in the MUTCD.

Exhibit 17-3 Bike Lane

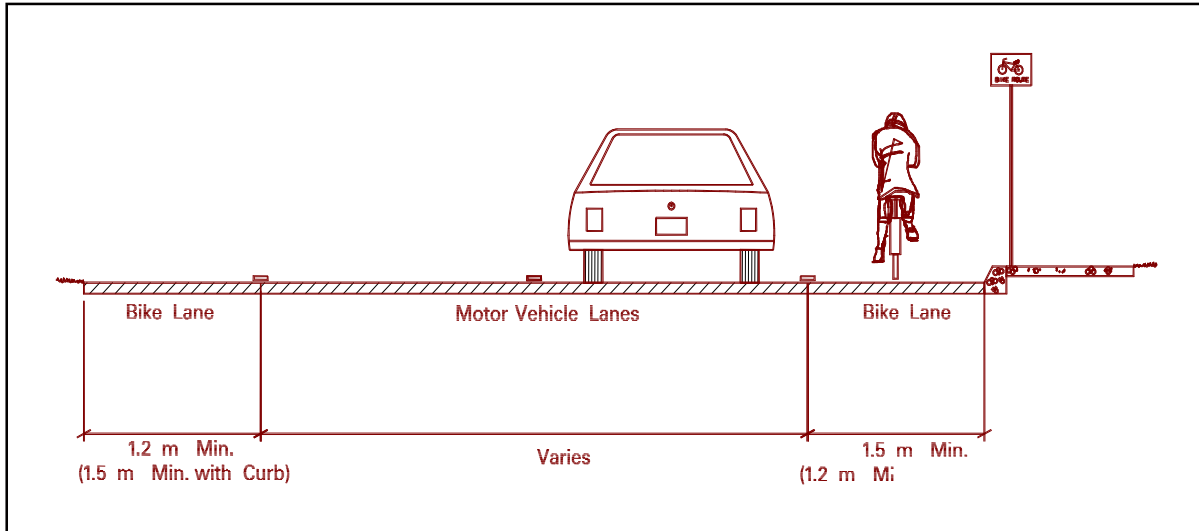

Exhibit 17-4 Bike Lane with On-Street Parking

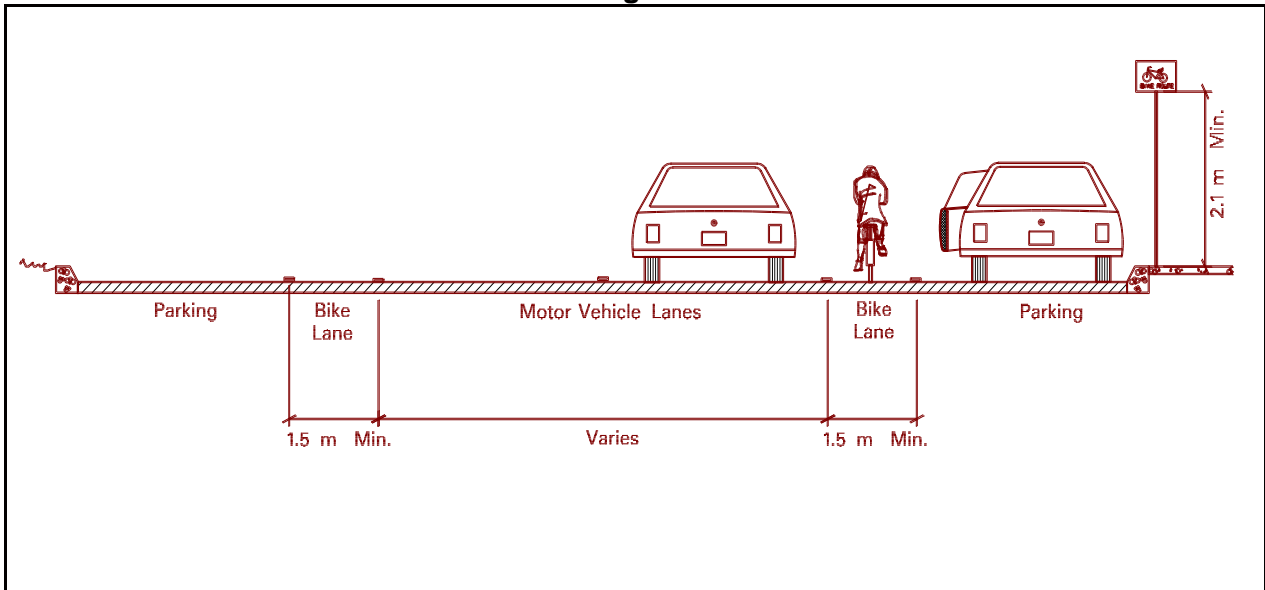

Exhibit 17-5 Typical Bicycle and Automobile Movements at Intersections

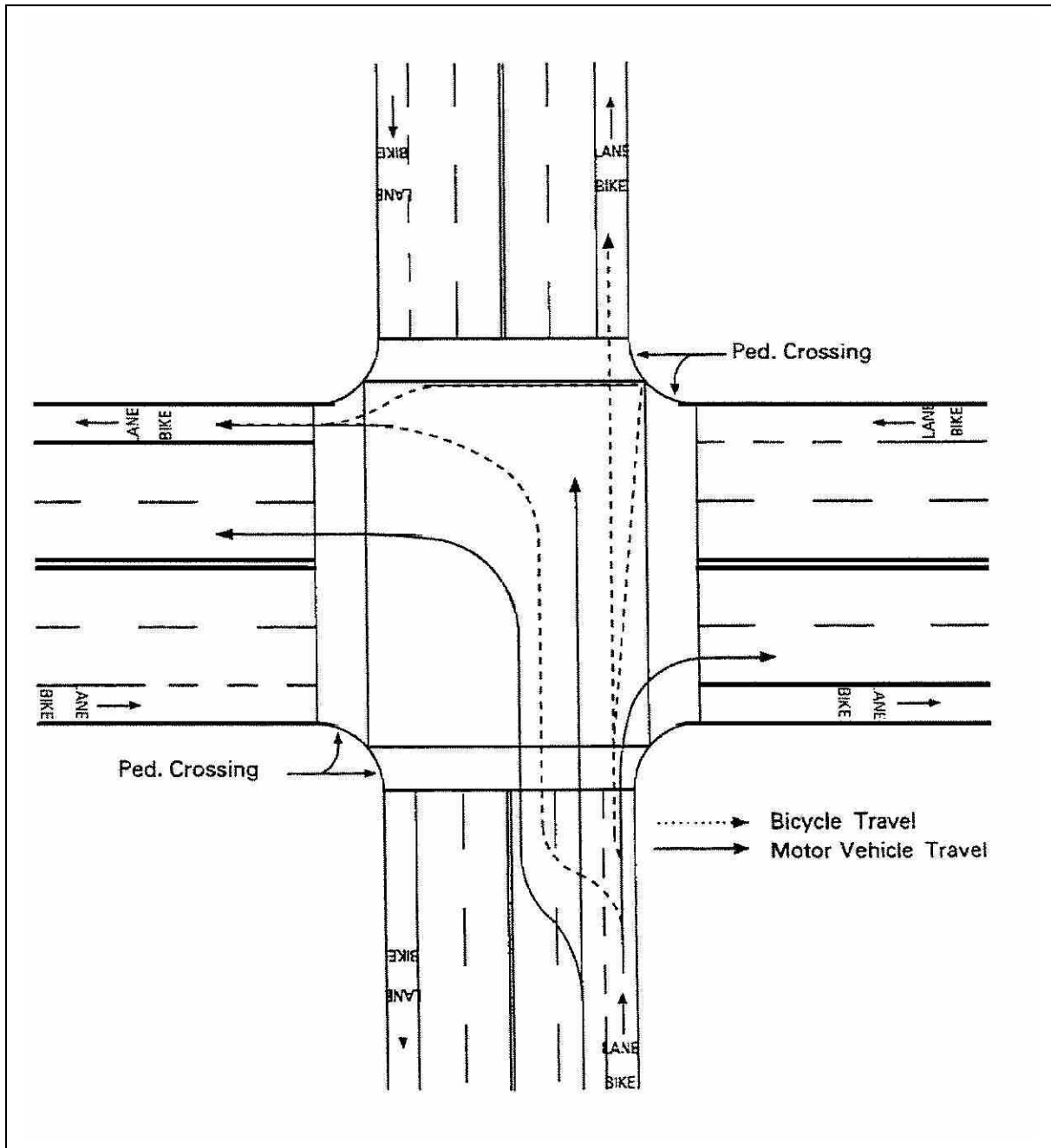
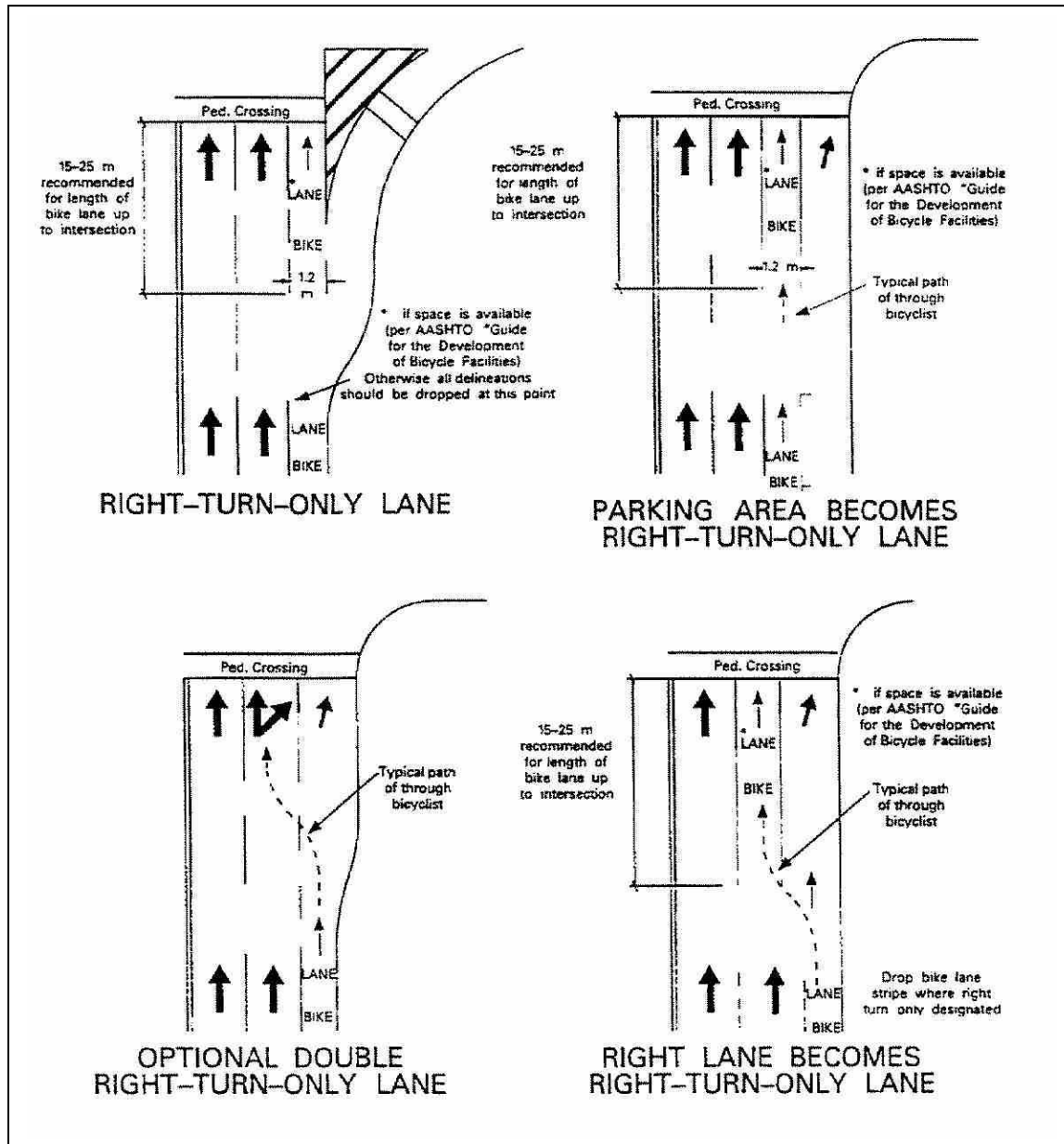

Exhibit 17-6 Bicycle Lanes Approaching Right-Turn-Only Lanes



17.4.8 Bicycle Routes

Bicycle routes are distinguished by their designation and signing as preferred routes through high demand corridors. The surface treatments and lane widths are especially important to assure the usability of designated bicycle routes.

In addition to providing a continuous route to destinations, signed bicycle routes should be consistent with an established plan. Bicycle routes are frequently mapped and locally advertised for bicycle commuting and touring, or as preferred routing through congested areas. Before a roadway (or existing bicycle facility such as a bike path) is signed as a bicycle route as part of a Department project, the designer should always consider including improvements such as minimum bicycle facility widths (where they are less than the minimum), safe drainage grates and railroad crossings, smooth pavements and bicycle responsive traffic control devices.

The need for, or existence of, a signed bicycle route will be identified in the project scoping and design approval documents. The establishment of a signed bicycle route will usually be based on the following criteria:

- The MPO, village, town, city or county having jurisdiction for each segment of the bike route has mapped the route as a part of a comprehensive bicycle plan.
- The route provides through and direct travel in bicycle-demand corridors.
- Surface imperfections have been corrected such as adjusting utility covers to grade, and installing bicycle safe drainage grates (see Chapter 8, Section 8.7.4.2 of this manual).
- The route will be periodically maintained by the maintaining authority at a rate that manages the accumulation of dirt, broken glass and other debris at the sides of the road.
- The lane and/or shoulder widths along the project are consistent with Sections 17.4.5 through 17.4.7, where applicable.

In order to provide improved safety, it may be desirable to remove on-street parking, or restrict it to hours when bicycling is least likely, especially in areas of critical width. However, these alternatives require an analysis of other project needs and coordination with local elected and enforcement officials, etc.

Refer to the current AASHTO "Guide for the Development of Bicycle Facilities" and Appendix I (Pedestrian and Bicycle Facility Scoping Guide) of the "Scoping Procedure Manual" for additional information and guidance on the provision of bicycle routes.

17.4.9 Bicycle Paths

A bicycle path is physically separated from motorized vehicular traffic by an open space or barrier and is either within the highway right-of-way or within an independent right-of-way. Bicycle paths should have minimal cross flow of motor vehicles.

The need for bicycle paths will be identified in the project scoping and/or design approval documents. Bicycle paths can meet transportation needs by providing commuting bicyclists with a shortcut through a residential neighborhood (e.g. a connection between two cul-de-sac

streets) or by providing bicycle access to areas that are otherwise served only by limited access highways closed to bicycles.

New bicycle paths are usually constructed by the Department only when bicyclists' needs can not be provided for on the roadway. Bicycle paths are normally constructed only when other governmental entities have requested them and are willing to maintain them, and when one or more of the following conditions are met:

- The bicycle path serves a transportation use (a recreational loop trail located entirely within a park is an example of a path that does not serve a transportation use).
- An existing bicycle path is severed or dislocated by the work of a Department project.
- The bicycle path is an essential environmental requirement mitigating impacts of a Department project.
- The bicycle path is being constructed at another agency's request and that agency has made the funding arrangements.
- Providing a bicycle path would be more economical than providing facilities for bicycling on a roadway and assurance can be obtained that the bicycle path will be maintained year round. The potential for use by others (pedestrians, etc.) should also be considered during design to assure the facility will adequately accommodate the intended use as a bicycle path.

FHWA concurrence must be obtained relative to the transportation purpose of every federal-aid bicycle path project. Furthermore, no federal-aid project can sever or destroy an existing major route for non-motorized traffic without FHWA concurrence of alternative route provisions, as required by 23 CFR 630.114(i). Design Approval Documents should provide appropriate discussions of these issues.

Where bicycle paths are proposed, the designer should refer to the current AASHTO "Guide for the Development of Bicycle Facilities" for information regarding the following:

- Separation between path and roadways
- Bicycle path and roadway intersections
- Path width and clearance guidelines
- Restriction of motor vehicles
- Design speed and curve radii
- Grades
- Horizontal/Vertical alignment and superelevation
- Sight distance
- Railroad crossings

In addition to AASHTO's guidance, the designer should consider the following:

- Paved, all-weather surfaces are preferable to crushed aggregate, sand, clay or stabilized earth. Unpaved paths should be developed using the shared-use path guidelines in Section 17.5. Unpaved bicycle paths provide a limited level of service, as they may cause instability problems for bicyclists with narrow tired bikes. These riders will often avoid unpaved paths when there is an adjacent roadway.

- Two-way bicycle paths should be at least 3 m wide. The edges of narrower paths quickly deteriorate as a result of weathering and wear by maintenance, police and emergency service vehicles. While bicycle paths are not necessarily designed as shared-use paths, they should desirably be 3.6 m wide when there is the expectation of unintended use by pedestrians and others. Consideration should also be given to providing additional width where there are steep grades.
- One-way bicycle paths should not be constructed unless they are clearly signed to indicate the direction of travel and a parallel path in the opposite direction is clearly marked, within sight and easily reached. Additionally, there should be assurance that one way travel will be enforced.
- When a bicycle path will closely parallel a roadway where bicycling is permitted, the designer should consider the use of "Share the Roadway" signs to alert motorists to the fact that bicyclists may also be using the road.
- When a bicycle path is provided immediately adjacent to a roadway, it may be necessary to provide a safe barrier between the roadway and path. The selected barrier should be of a type that will minimize injury if a bicyclist using the path accidentally hits it (i.e., the barrier does not have protruding edges). If a bicycle path is placed adjacent to a roadway with an existing guide rail, it may be necessary to provide protection for bicyclists from striking the back side of the guide rail.

Acceptable options for barriers located 2 m or closer to the edge of a bicycle path are heavy post (timber) with blocked out corrugated guide rail or a suitable type of concrete median barrier. The latter has a smooth back side with no protrusions that helps to minimize injury to bicyclists if they hit it. When timber posts are used with blocked out corrugated guiderail, the edges should be beveled to achieve a 30 mm chamfer to blunt the edges. Also, a continuous run of 50 mm x 300 mm timbers should be provided on the backside of the timber posts (however, theft should be considered).

When a barrier will be more than 2 m from a bicycle path, the barrier may be selected based on highway/motor vehicle considerations provided the deflection distance of the barrier does not extend into the path. See Chapter 10, Section 10.2.2 of this manual for further guidance.

- In some instances, it may be necessary to provide design features to warn of dangerous conditions or to reduce bicyclists' speed. These features may be used where there are steep grades, sharp curves, where visibility is limited, or at intersections with roadways or pedestrian facilities. These features include, but are not limited to, pavement striping and surface treatments, signing and vertical elements such as bollards. If vertical elements are used, they must be visible during low light conditions to help assure adequate stopping sight distance and should be used in conjunction with signing and/or striping to help warn bicyclists.

17.4.10 Supplemental Bicycle Facilities**17.4.10.1 Bicycle Parking Facilities**

Bicycle parking facilities may be provided as is appropriate and convenient at well lighted locations when a municipality, agency or other public entity will agree to maintain them. Parking facilities should be durable; offer protection from theft, damage and weather; and be consistent with the maintaining entity's standard designs.

Types of bicycle parking facilities:

1. Long-term parking: Bicycle parking facilities at places such as transit stations and park and ride facilities should consist of long term rental or leased bicycle lockers and/or attended storage areas.
2. Short-term parking: Public libraries, recreation areas and downtown retail areas or streets are examples of locations where appropriate short-term parking facilities should be considered. Short-term parking areas should be convenient and near building entrances or highly visible areas for safety and bicycle security. If bicycle parking is not properly designed and located, bicyclists will use trees, railings and other appurtenances. This practice can damage facilities and create obstructions for pedestrians. In addition, this may result in bicycles being damaged by motor vehicles. Bicycle racks, and short term rental lockers are usually adequate for these locations.

Bicycle racks should be constructed of sturdy material and be difficult to dismantle. They should provide opportunities to lock both the frame and wheels with a U-lock type lock as well as a lock and chain combination.

Bicycle lockers should be constructed of durable materials not readily subject to vandalism and weather.

Care should be given in selecting the location of racks, lockers and other bicycle facilities to help ensure that bicycles will not be damaged by motor vehicles, stolen, vandalized, etc. Bicycle parking facilities should not interfere with pedestrian flow and should provide users easy access to their parked bicycles.

17.4.10.2 Signing and Pavement Marking

Guidance on signing and pavement marking can be found in the MUTCD and in the current AASHTO "Guide for the Development of Bicycle Facilities". The Regional Traffic Engineer should also be consulted.

17.4.10.3 Lighting

Lighting should be considered where significant levels of night riding can be expected, especially near colleges, and along commuter routes. Lighting may help to alleviate possible

bicycle/motor vehicle conflicts at intersections. Lighting contributes to a safe bicycling environment by illuminating the area so that the bicyclist may see the roadway or bike path alignment, surface conditions and obstacles. Lighting may also help to alleviate safety and security concerns in some areas.

All lighting decisions should be consistent with the Traffic Engineering and Safety Division's "Policy on Highway Lighting". The designer should also consult Chapter 12 of the Highway Design Manual for guidance on lighting issues.

17.4.10.4 Restrictions to Motor Vehicle Traffic

Unauthorized motor vehicles are banned from bicycle or shared-use paths. This is a federal-aid requirement of 23 CFR 652.7(b)(3)(ii). Barriers should be provided. However, barrier designs should accommodate entry by emergency and maintenance vehicles. The barriers used should be consistent with the setting of the path and with the maintaining entity's standards where possible or applicable. Any barriers that are used should be visible to bicyclists both during daylight and at night. Avoid placing barriers where sight distance is limited or use advance pavement markings and/or signs to warn bicyclists. To allow access to paths by adult tricycles and bicycle trailers, a spacing between barriers of 1.5 m should be used. A wider spacing may not prevent access by motor vehicles and a narrower spacing may present a hazard to less proficient bicyclists. Appropriate exclusion signs should also be considered. Refer to the NYS MUTCD for information regarding the use of exclusion signs.

17.4.10.5 Rest Areas

Provision of rest areas should be considered on long, uninterrupted bicycle and shared-use paths. Locations should be identified during project scoping and preliminary design, and should be integrated with other transportation facilities where appropriate. For guidance, refer to the current AASHTO publication, "A Guide for Transportation Landscape and Environmental Design."

17.4.10.6 Railings

Bridge railing heights on bicycle paths and shared-use paths should be a minimum of 1.4 m. Railing heights at other locations along bicycle and shared-use paths where railings are considered necessary or appropriate should also be 1.4 m (see Fig. 17-7). There are no specific warrants for installing railings other than on bridges. Designers should exercise professional judgment and should consider the steepness and height of drop-offs adjacent to paths, their lateral distance from the path, their surfaces (e.g., rock slopes, etc.), whether they are on the outside of horizontal curves (especially at down grades), etc. Railing heights on highway bridges that also include bicycle lanes or designated bicycle routes should also be 1.4 m. Designers should also consider using 1.4 m high railings on highway bridges that do not have bicycle lanes or designated bicycle routes, but do have more than occasional bicycle traffic, especially if a significant amount of that use comes during concentrated periods of time (e.g., bridges that are popular for bicycle commuting or are often used for group rides, etc.).

Railings designed to provide protection for bicyclists should not have vertical balusters that could snag bicycle pedals. Railing designs comprising horizontal rails without (or with setback) balusters may be used in these instances. For additional information on railings, the designer should consult the regional landscape architectural staff, the Regional Structures Engineer, the current Bridge Detail Sheets and the current NYSDOT "Standard Specifications for Highway Bridges".

17.4.10.7 Drainage Grates

All drainage grates should be of a design that does not catch a bicycle wheel when the grate is crossed. For guidance on bicycle safe drainage grates, FHWA's "Selecting Roadway Treatments to Accommodate Bicycles" and "Bicycle Safe Grate Inlet Study", Vol.'s 1-4 should be consulted, as well as Chapter 8, Section 8.04.06 of this manual.

Exhibit 17-7 Safety Railings along Bicycle and Shared Use Paths

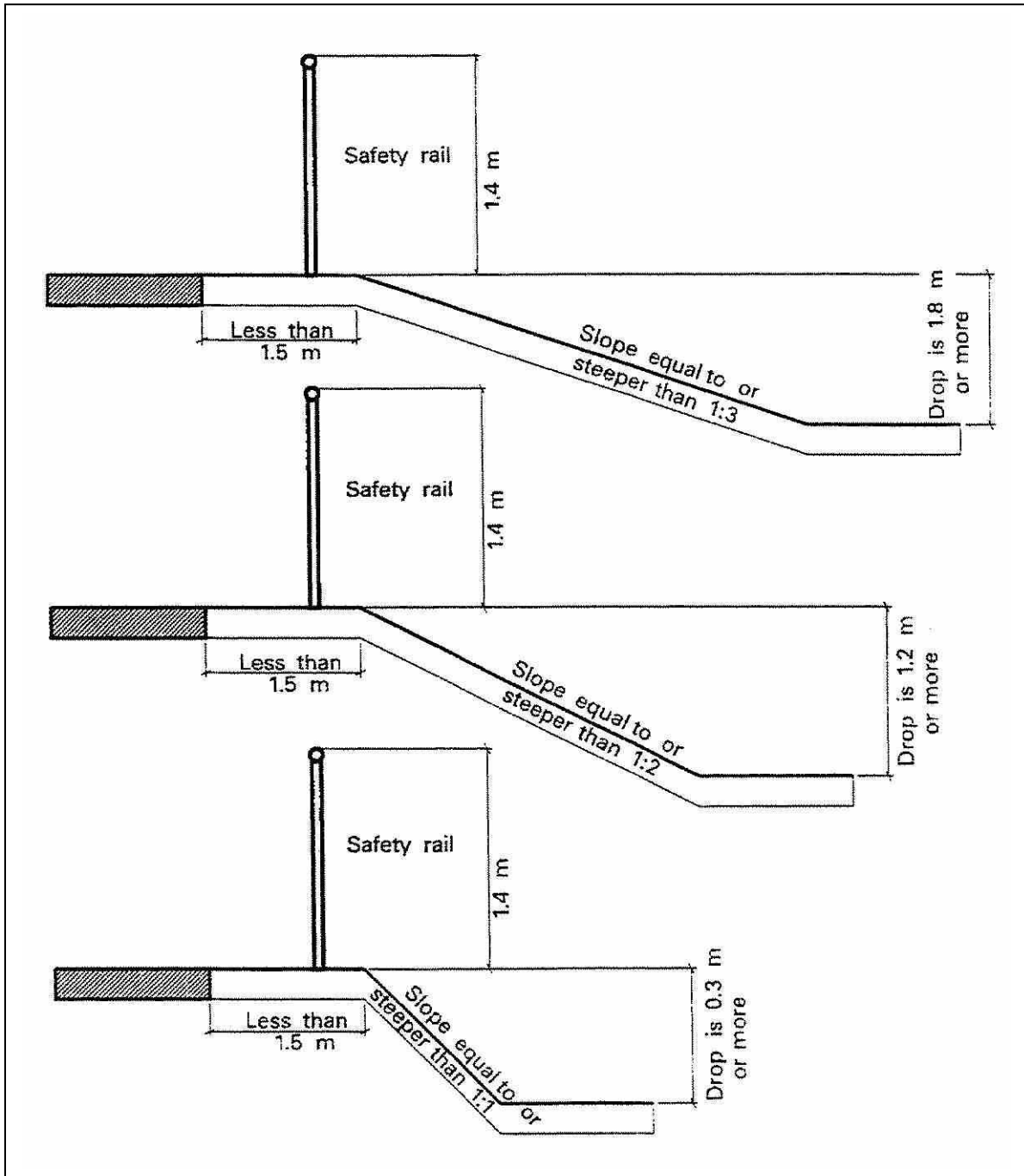

17.5 RECREATIONAL WALKWAYS AND SHARED-USE PATHS

The most common recreational walkways and shared-use paths encountered and altered as part of Department projects are pedestrian/bicycle paths, facilities associated with trail head parking, segments of hiking trails, fishing access sites and similar facilities.

The Department's minimum recommended width for shared-use paths is 4 m.

17.5.1 Access for Persons with Disabilities

Specific accessibility standards for recreational facilities, including recreational walkways have not been adopted. However, it is established that the ADA affects these kinds of facilities. In general, recreational walkways and shared-use paths must be made as accessible as feasible. The current ADAAG requirements should be considered as minimum requirements for design.

Departures from ADAAG's minimum requirements should only be made where it is infeasible or inappropriate to strictly apply them. Considerations include the nature and extent of development surrounding a recreational walkway or shared-use path (i.e. urban, suburban, rural, undeveloped or wilderness), distance between access points, nature of the terrain, etc.

Regional landscape architectural staff or the Landscape Architecture Section of DQAB should be contacted for advice and current information about the status of any accessibility related regulatory requirements.

17.5.2 Design Considerations

Recreational walkways and shared-use paths should be designed to accommodate the users identified in the project scoping and Design Approval Documents. Whenever possible, shared-use paths that are intended to accommodate pedestrians and higher speed users (bicyclists, in-line skaters, etc.) should be designed to minimize the potential for conflicts. Where separate facilities are not feasible, a shared-use path should incorporate additional width, signing, and possibly striping to minimize conflicts. For example, the designer should consider widening the walkway or path where conflicts between pedestrians, bicyclists, in-line skaters, joggers, etc. are most likely to occur, such as at sharp curves, the bottom of downgrades and other areas where visibility may be limited. Recommendations regarding the use of warning signs and pavement markings for these instances may be found in the MUTCD.

Consideration should also be given to designing shared-use paths to accommodate emergency and maintenance vehicles in areas where their access may be needed. Designers must also consider establishing barriers to prevent the use of unauthorized motor vehicles. This is a federal-aid requirement of 23 CFR 652.7(b)(3)(ii). See Section 17.4.10.4 for guidance.

All-weather paved surfaces are usually preferable to crushed aggregate, sand, clay or stabilized earth where they serve a relatively large number and wide variety of users (i.e. bicyclists, in-line skaters, pedestrians, etc.). However, there has been a recent increase in the use of wider tire bicycles, such as mountain and hybrid bikes. Therefore, non-paved shared-use paths may be

alternatives in lightly developed or undeveloped areas where the scoping documents indicate that use of the path is expected to be relatively light.

Bicycle speeds on unpaved paths are normally lower than on paved paths, and as a result, may cause fewer conflicts between bicyclists and pedestrians. The materials or surfaces usually preferred for unpaved paths are stabilized earth or ground limestone depending on anticipated use and local availability. The Regional Geotechnical Engineer should be consulted for recommendations.

If a shared-use path is provided immediately adjacent to a roadway, it may be necessary to provide a barrier type that will minimize injury if someone using the path accidentally hits it.

1. Acceptable options for barriers located 2 m or closer to the edge of the shared-use path are: heavy post (timber) with blocked out corrugated guide rail or a suitable type of concrete median barrier. The latter has no protrusions and a smooth back side that helps to minimize injury if a path user hits it. When timber posts are used with blocked out corrugated guide rail, the edges should be beveled to achieve a 30 mm chamfer to blunt the edges. Also, on the backside of the timber posts, a continuous run of 50 mm x 300 mm timbers should be provided (however, theft should be considered).
2. When a barrier will be more than 2 m from a path, the barrier may be selected based on highway/motor vehicle considerations provided the deflection distance of the barrier does not extend into the path. See Chapter 10, Section 10.2.2 of this manual for further guidance.

On shared-use path bridges and other locations along shared-use paths that accommodate bicycles, railing heights should be a minimum of 1.4 m (see Fig. 17-5). For additional information on the various kinds of railings that may be appropriate along shared-use paths, the designer should consult Chapter 18 of this manual, the regional landscape architectural staff, Regional Structures Engineer and the current NYSDOT "Standard Specifications for Highway Bridges".

One-way shared-use paths that are less than the recommended minimum width of 4 m and that are separated by distance, a roadway or by a visual barrier, should be avoided. Compliance with the intended direction of traffic will normally be mediocre at best and the incidence of conflicts will increase with reduced width.

Designers should refer to Section 17.4.10 for information about the following supplemental bicycle facilities that may be included in shared-use path projects:

1. Bicycle parking facilities,
2. Signing and pavement marking,
3. Lighting,
4. Restrictions to motor vehicle traffic,
5. Rest areas, and
6. Drainage grates.

For further guidance on the design of shared-use paths that are intended to accommodate bicycling, the designer should reference the current AASHTO "Guide for the Development of Bicycle Facilities".

17.5 CONSTRUCTION ISSUES

FHWA regulations ((23 CFR 652.5) require that provision for safe accommodation of bicyclists be given full consideration during construction. HDM Chapter 16, Section 16.4.4.2 contains a discussion on the maintenance and protection of bicycle traffic during construction. Work zone traffic control diagrams for bicyclist accommodation can be found at:
<http://www.dot.state.ny.us/traffic/workzone/pedaccdiag.html>.

17.6 MAINTENANCE OF BICYCLE FACILITIES

The Department of Transportation generally does not maintain bike paths, bicycle parking facilities, recreational walkways or shared-use paths. Therefore, if these facilities are to be built, they usually must be approved by the municipality or agency that will be responsible for their maintenance. The governmental entity that will assume the maintenance responsibility for these facilities must pass a resolution and enter into a Memorandum of Understanding or other agreement. This should be discussed with the involved entity during the project scoping phase or as early in the design phase as possible.

An original signed resolution or other appropriate agreement must be received by the Design Quality Assurance Bureau, PS&E Section, by Phase VI of the design, for bicycle paths, bicycle parking facilities, recreational walkways or shared-use paths to be included in the project. Refer to Chapter 14 for an example municipal resolution. Delays in receipt of necessary resolutions may result in a delayed project letting.

17.7 REFERENCES

1. A Policy on Geometric Design of Highways and Streets, 1994, American Association of State Highway and Transportation Officials, Suite 225, 444 North Capitol Street, N.W., Washington, DC 20001.
2. Americans With Disabilities Act Accessibility Guidelines for Buildings and Facilities, December, 1993, Landscape Architecture Bureau, New York State Department of Transportation, State Campus, Albany, NY 12232.
3. Bicycle Safe Grate Inlet Study, Federal Highway Administration, Washington, DC 20590
Vol. 1, Hydraulic and Safety Characteristics of Selected Grate Inlets on Continuous Grades, Report No. FHWA-RD-77-24, June, 1977.
Vol. 2, Hydraulic Characteristics of Three Selected Grate Inlets on Continuous Grades, Report No. FHWA-RD-78-4, May, 1978.
Vol. 3, Hydraulic Characteristics of Three Selected Grate Inlets in a Sump Condition, Report No. FHWA-RD-78-70, September, 1978.
Vol.4, Hydraulic Characteristics of Slotted Drain Inlets, Report No. FHWA-RD-79-106, February, 1980.
4. Bicyclist and Pedestrian Safety and Accommodation, NHI Course No.38061. Publication No. FHWA HI-93-021, August 1993, US Department of Transportation, Federal Highway Administration, Washington, DC 20590.
5. Geometric Design Policy for Bridges, March 1996, Structures Design and Construction Division, New York State Department of Transportation, State Campus, Albany, NY 12232.
6. Guide for the Design of High Occupancy Vehicle and Public Transfer Facilities, 1983, American Association of State Highway and Transportation Officials, Suite 225,444 North Capitol Street, N.W., Washington, DC 20001.
7. Guide for the Development of Bicycle Facilities, Fourth Edition, 2012, American Association of State Highway and Transportation Officials, Suite 225, 444 North Capitol Street, N.W., Washington, DC 20001.
8. Guide for Transportation Landscape & Environmental Design, American Association of State Highway and Transportation Officials, Suite 225, 444 North Capitol Street, N.W., Washington, DC 20001.
9. New York State Manual of Uniform Traffic Control Devices, July, 1983, Traffic Engineering and Safety Division, New York State Department of Transportation, State Campus, Albany, NY 12232.
10. New York State Uniform Fire Prevention and Building Code, 1995, New York State Department of State, 162 Washington Avenue, Albany, New York 12231.
11. Policy on Highway Lighting, December, 1979, Traffic Engineering and Safety Division, New York State Department of Transportation, State Campus, Albany, NY 12232.

BICYCLE FACILITY DESIGN

12. Pedestrian and Bicycle Facility Scoping Guide, New York State Department of Transportation, Albany, NY 12232.
13. Selecting Roadway Design Treatments to Accommodate Bicycles, Pub. FHWA-RD-92-073, January 1994, US Department of Transportation, Federal Highway Administration Research and Development, Washington, DC 20590.
14. Standard Specifications for Highway Bridges, 1994, Structures Design and Construction Division, New York State Department of Transportation, State Campus, Albany, NY 12232.
15. Code of Federal Regulations, Title 23, 1995, for sale by the U.S. Government Printing Office, Superintendent of Documents, Washington, DC 20402.
16. Highway Capacity Manual, Special Report 209, 1994, Transportation Research Board, National Research Council, 2101 Constitution Avenue, N.W., Washington, D.C., 20418.